

# Project Report

Control Systems

Project Title: Smart Irrigation System for Plants.

## Objective

The objective of this project is to design and simulate system based proportional plus integral controller using programmable logic controller (PLC). The subject of this project is to develop a smart irrigation system for plants using PLC.

## Background Study

This project demonstrates a PI controller base automated irrigation system for plants. This system is developed by considering a single plant. Our purpose of this project is to water the plant based on its soil humidity.

A plant needs a moistured soil. For that reason, we need to water the plants. But we cannot perfectly water the plants as per its requirements. Sometimes the moisture level exceeds the limits or sometimes it fails to reach the proper moisture level. To acquire the desired moisture level, we need a system that will water the soil considering its humidity. We need to set a suitable humidity for the soil. The system will sense the humidity of the soil and it will try to reach the desired humidity level by watering. We can design the system using PI controller. The system model is shown below,

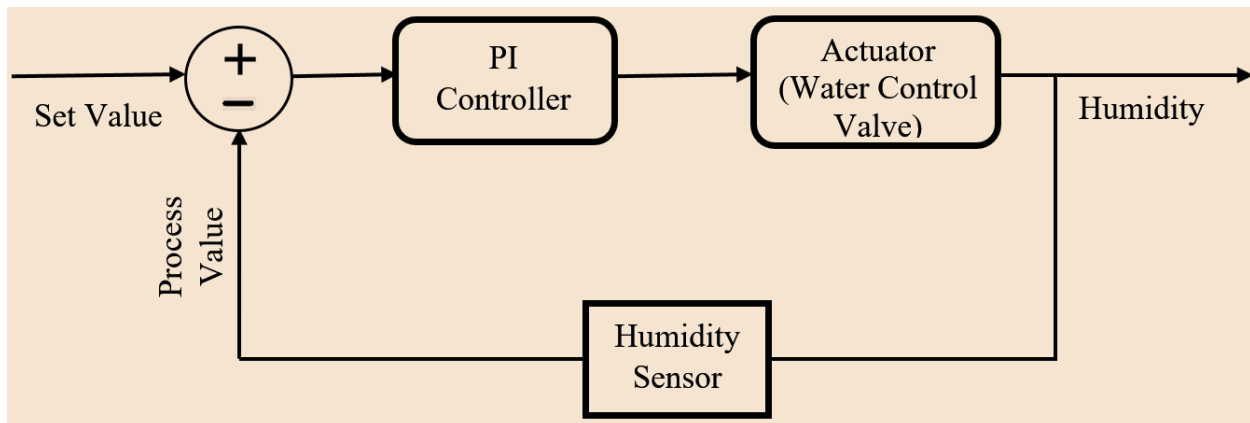

Figure 1: Block Diagram

In the above figure, the set value is the desired humidity level. The process value comes from the humidity sensor. The sensor will detect the initial humidity of the soil. If the humidity of the soil is less than the fixed value then the PI controller will generate a signal which will turn on the water control valve. The valve will provide a certain amount of water to raise the humidity to a certain level. The PI controller checks whether the fixed value is equal to the sensor's value. If the values are not equal then the PI controller tries to make it equal as it works to reduce the steady state error. In real life scenario we can only increase the humidity by using this system. We can never reduce a humidity level using the system.

## Equipment

### Sensor : Humidity Sensor (HS 1101) [1]

This sensor has a lot of features. Such as,

- Full interchangeability with no calibration required in standard conditions. [1]
- Instantaneous desaturation after long periods in saturation phase. [1]
- Compatible with automatized assembly processes, including wave soldering, reflow and water immersion. [1]
- High reliability and long-term stability. [1]
- Patented solid polymer structure. [1]
- Suitable for linear voltage or frequency output circuitry. [1]
- Fast response time. [1]
- Individual marking for compliance to stringent traceability Requirements. [1]



**HS 1101**

### Actuator : Water Level Control Valve

In the actuator part we will need a few equipment. First of all, we need a 20/30-liter water reserve tank. Then we will have another small tank which can store 100 mL of water. When the PI controller output will generate a on signal to the actuator and it will turn off the valve of the big reserve and turn on the small reserve. When the off signal will be generated the actuator will turn off the small reserve and turn on the big reserve. In summary if the actuator is on then 100 mL of water flow will be provided to the soil, and if the actuator is off then the water will flow form the big reserve to the small reserve. So, the small reserve will be filled.

### Working Principle

The system is based on relative humidity. We need to settle the value of relative humidity using PI controller. Here, we are going to measure the humidity in percentage. So, the range of humidity is 0-100%. We have divided the values in 20 portions and each portion is of 5%. Here we are assuming that to increase the humidity level to 5% we need 100 mL of water. If the initial value is 20% and the set value is 25% then the PI controller will send a signal to the actuator. The actuator will turn ON once and it will provide 100 mL of water to increase the humidity of the soil for 5%. If we want to increase 10% then the actuator will turn ON two times. So, it will provide 200 mL water. Ultimately this will increase 10% humidity. So, the equation of the sensor is,

$$\text{Humidity} = (\text{No. of times actuator turning on} * \text{each portion of RH}) + \text{Initial humidity}$$

We have created a basic structure of this system in PLC considering each portion of humidity as 1%. So that the humidity will gradually increase. In the basic structure we kept it simple. This just summarizes the working principle. The PLC diagram is shown below,

*\*Note : We have assumed the values as there are no specific datasheet is available.*

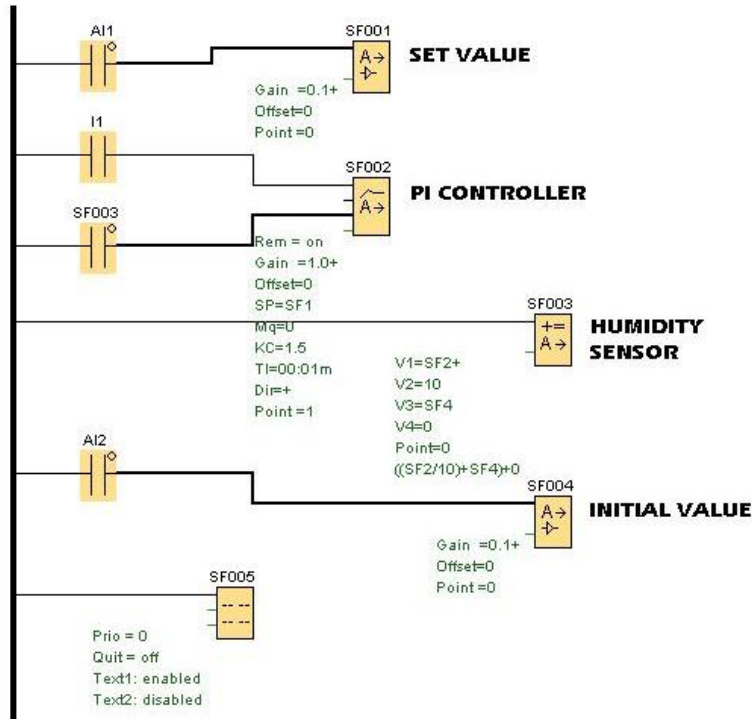

Figure 2: Basic Structure.

We have not mentioned the actuator in this section. This is the simple version of the system. In the set value we need to set a value of relative humidity. Manually we can set an initial value. Here the PI controller automatically changes the value of the sensor according to the set value to reduce the steady state error. The simulation results for this structure are,

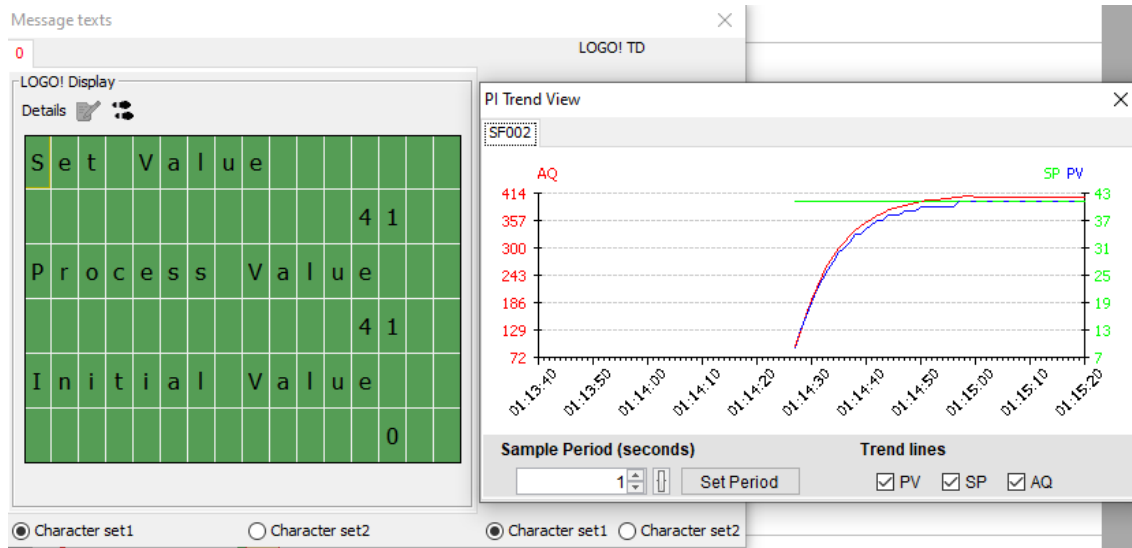

Figure 3: Simulation results.

We have chosen an arbitrary value 41 as set value and the PI controller changed the process value according to the set value gradually. By using the concept of this basic structure, we have designed our desired system.

# Design Methodology

The Ladder diagram for the system is shown below,

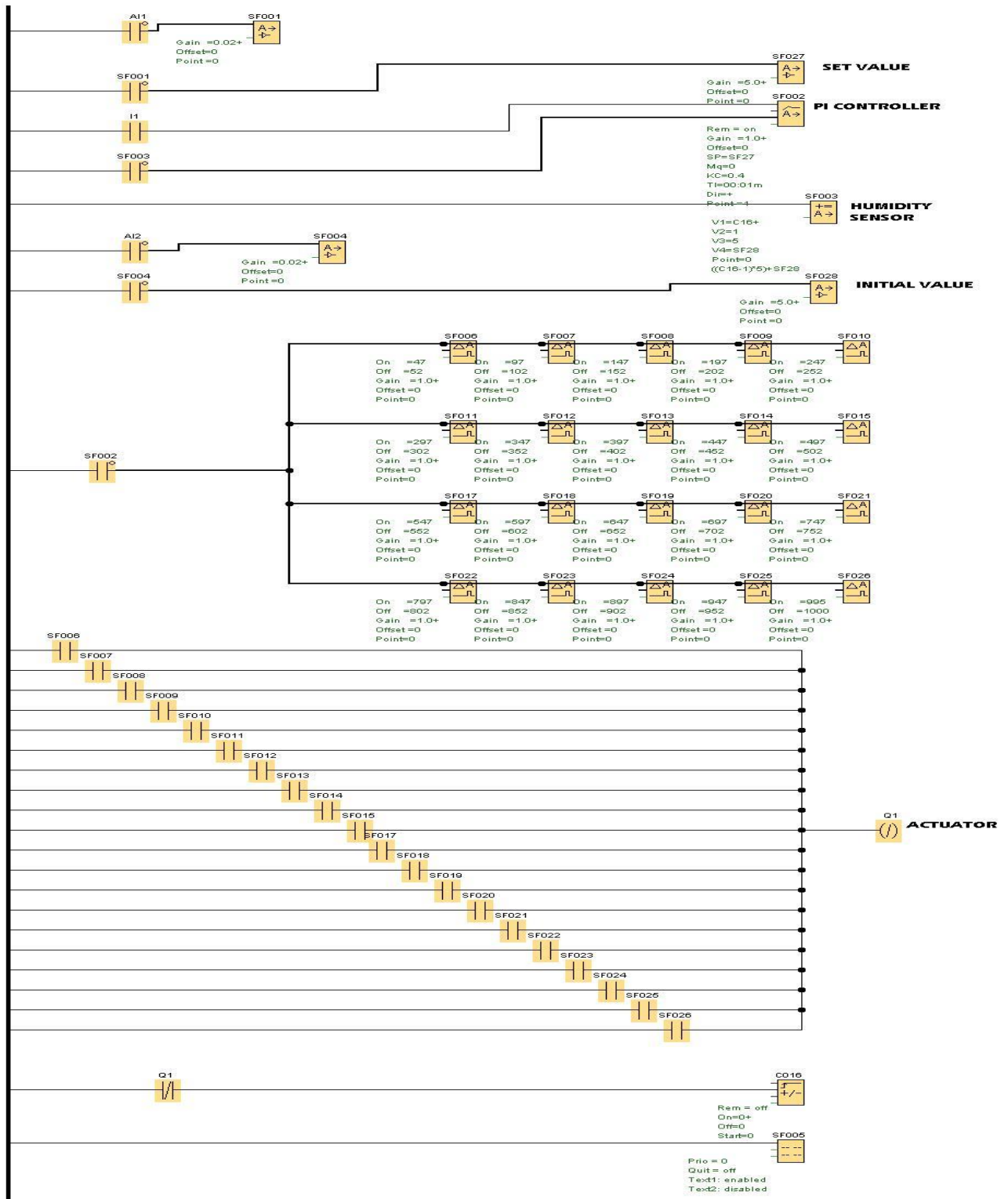

Figure 4: Ladder diagram.

For the set value, the analog amplifier SF001 is ranged from 0-20. Then we have amplified the output of the SF001 by 5 times using SF027. For that the set value is ranged from 0-100. The difference between two consecutive values will be 5.

For the initial value, the analog amplifier SF004 is ranged from 0-20. Then we have amplified the output of the SF004 by 5 times using SF028. For that the initial value is ranged from 0-100. The difference between two consecutive values will be 5.

In the PI controller SF002, the set value is SF027 and the process value is the humidity sensor SF003. The PI controller's range is from 0-1000. So, if we want to increase the value of the humidity for 5 then the output of the PI controller will be around 50.

Here we have used 20 analog comparators which will generate on/off signals comparing the values of the PI controller. We have set the values of when the actuator should turn on and off according to the following table.

On	47-51	97-101	147-151	197-201	247-251	297-301	347-351	397-401	447-451	497-501
Off	52	102	152	202	252	302	352	402	452	502

On	447-551	597-601	647-651	697-701	747-751	797-801	847-851	897-901	947-951	995-999
Off	552	602	652	702	752	802	852	902	952	1000

*\*Note: We have used these ranges as the PI controller output increases very fast when the error between the set value and process value is higher.*

Whenever the actuator turns on then 100 mL of water will be provided to increase the humidity for 5%. We have used a counter to count how many times the actuator is turning on. Here for the actuator we have used an inverted output relay coil. So initially the counter will count 1.

In the humidity sensor we have used a mathematic instruction SF003. Here we have used an equation using the output of the actuator. The equation is,  $(C016-1)*5 + SF028$ . As initially the counter is always 1 so we have deducted 1 from the counter value and multiplied it with the portion size 5 which we have mentioned earlier. And added the initial value with it.

We have added a message text which will show the values of the set value, process value and the initial value.

If we set a value of humidity 5%. And our initial value is 0%. Then the humidity sensor value will be zero initially. The PI controller will increase gradually and when it will reach the range of 47-51 the actuator will turn on once and the value of the counter will be 2. For that the value of the humidity sensor will be 5. So, the steady state error will be zero.

## System Performance

We can observe the performance by considering the simulation results for different cases.

### Case 1: Set value 10% ; Initial value 0%

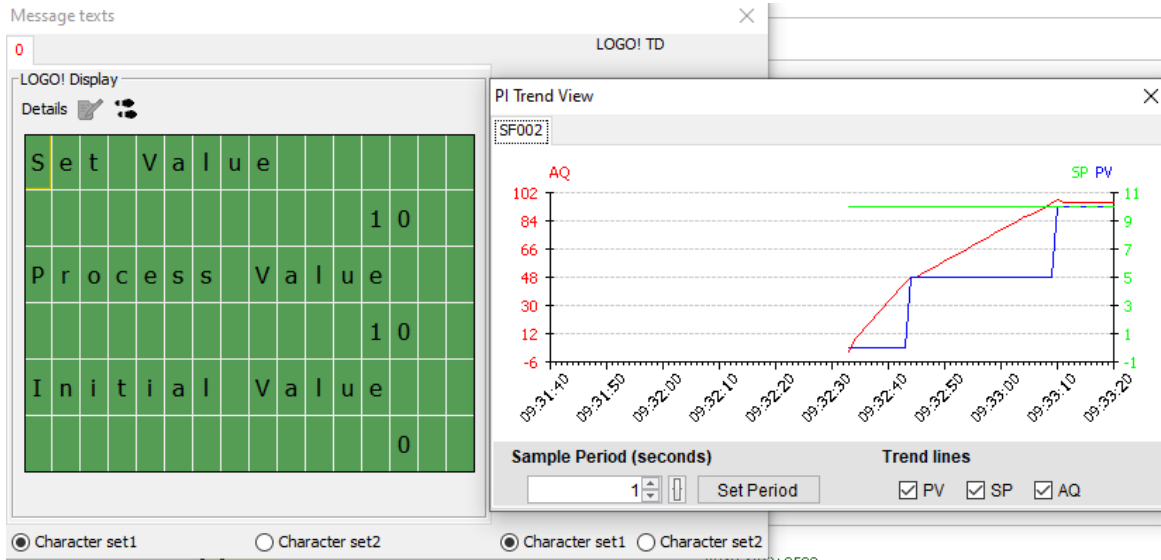

Figure 5: Case 1.

Here the process value increased in 2 steps. As the set value is 10. To obtain the value the actuator needs to be turn on twice. Finally, we can see that the steady state error is zero.

### Case 2: Set value = Initial value.

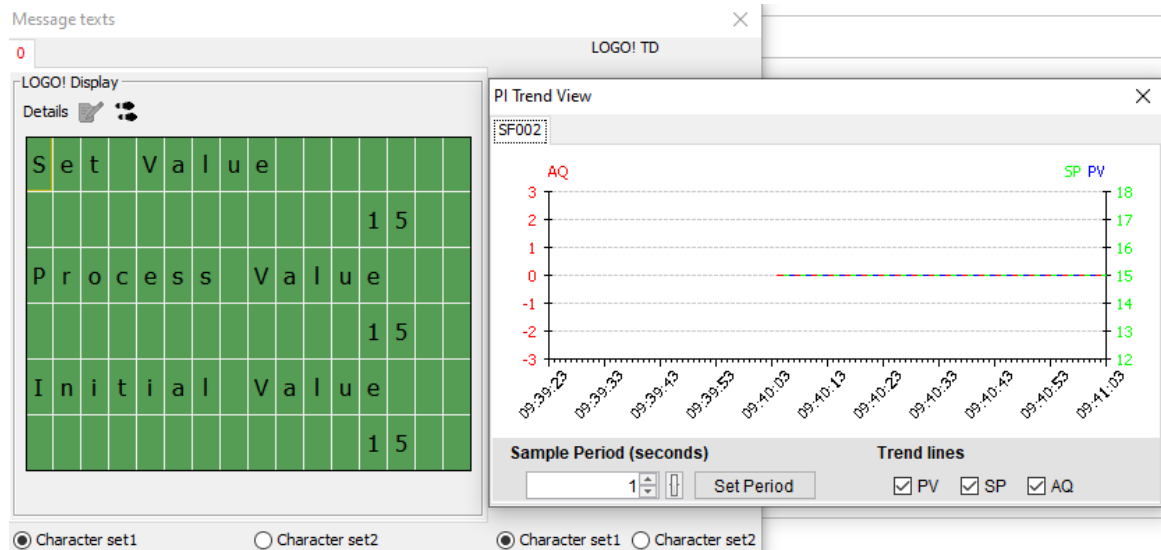

Figure 6: Case 2.

In this case the set value and the initial value is equal. So, there is no error. For that reason, the PI controller output is zero. We can see that the graph is a constant straight curve which is obvious.

### Case 3: Set value 100% ; Initial value 0%

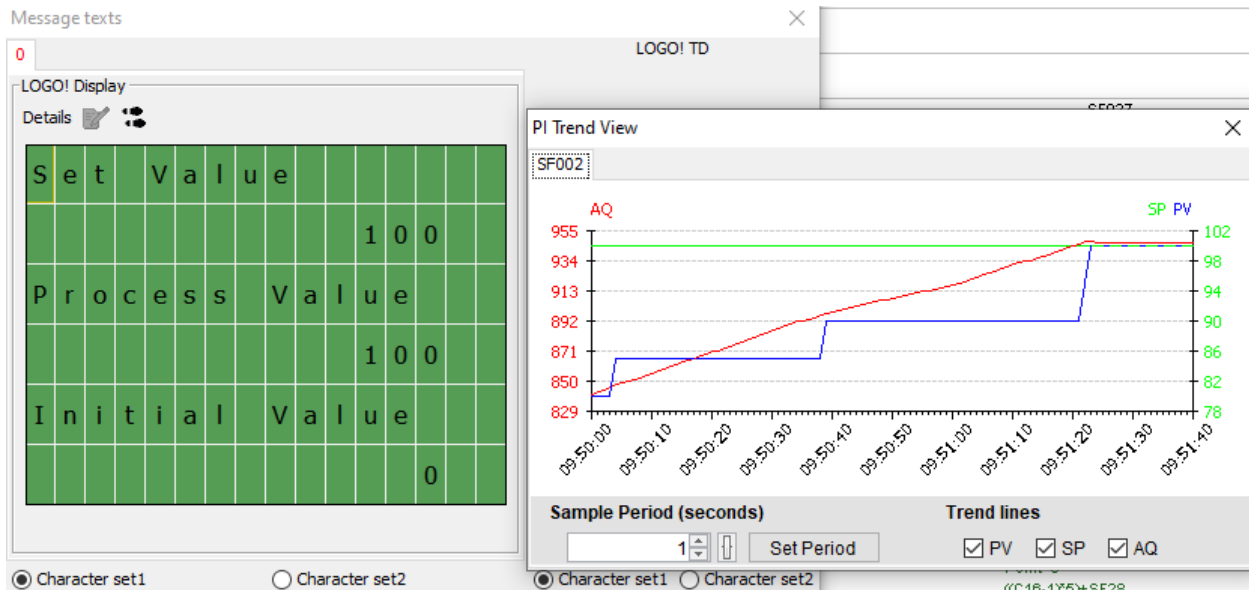

Figure 7: Case 3.

This is the most extreme case for our system. It had to turn on the actuator for 20 times to reach the desired level.

### Limitations

We have a few limitations such as,

- The system will not work if the initial humidity is already higher than the desired humidity; Neither in real life or in simulation.
- In the basic structure if we reduce the set value then the process value also reduces accordingly, which is not tangible in our case. After the process value reaches the desired value, if we reduce the set value then there will be no change.
- If the process value reaches its maximum point the system cannot change any values. We can add a reset switch to the counter to reset the system.
- In the simulation results we can see that the process values are not increasing gradually. Because we did not cut smaller portions of the humidity. If we could use 1% as a portion instead of 5% then the values would increase gradually. To do that in PLC we need 100 analog comparators instead of 20. To avoid the complications, we used 5% as a portion. We would also need to change the water reserve in the actuator side. If the portion changes to 1% then the actuator will turn on 100 times. Calculations would be different for that case.
- Our system can be used for a single plant at a time.

## Alternative Solution

1. We can use different methods to water the plants. We can use sprinklers or we can use water pumps. But in these cases, there is a high chance that the watering could exceed the limit. But in our case only a specific amount of water will be provided. So that there is no chance of go beyond the limits.
2. There are a lot of sensors available in the market which can measure humidity. We could use a sensor named as HR202L. This sensor's operating range of humidity is 20-95%. But HS1101 has a wide range of 0-100%. HR202L has a 5% accuracy issue. And Its stability decreases 1% per year. Considering these parameters, we did not use this sensor.

## Conclusion

In this project we have made a system to water the plants as per its requirements. We have used PI controller to serve the project outcomes. We have a few limitations as well which we have mentioned. We have approached different design methods. The system performance is evaluated by considering different cases. We could not find any proper data of how much water is needed to increase a certain amount of humidity. So, we have assumed the values with the prior consent of the instructor. We have also mentioned about an ideal case in the working principle part. All the designs are made with PLC ladder diagram. In ideal case the response time is suitable. But with actuators in the design methodology the response time is a bit slow.

## References

- [1] "HS1101 Datasheet PDF - Datasheet4U.com." <https://www.datasheet4u.com/datasheet-pdf/Humirel/HS1101/pdf.php?id=172182> (accessed Aug. 25, 2021).
- [2]"HR202L Datasheet PDF - Datasheet4U.com." <https://www.datasheet4u.com/datasheet-pdf/AOSONG/HR202L/pdf.php?id=1298963> (accessed Sep. 01, 2021).